

## COMBINATION AIR VALVE BARAK, MODEL DG-10 1"



### GENERAL INSTRUCTIONS

Routine service is an integral part of the standard procedure for maintenance of a water supply system.

Recommended routine maintenance— once or twice a year, according to the quality and type of the fluids in the system.

### PROCEDURE

Close the service valve under the valve base before servicing.

Turn the valve body (1) counterclockwise, release and remove.

From inside the valve body (1), remove the clamping stem (4) and carefully pull out the float (5) with the attached rolling seal (3).

Check the soundness of the rolling seal (3) by washing it with water and examining it. Replace the rolling seal in case it is torn.

Wash the body (1) and the float (5) with clean water and examine it for damage.

Replace the float (5) if it is damaged.

Clean the drainage elbow (2) to remove insects and debris.

Return the float (5) with the attached rolling seal (3) to its original position in the valve body (1) and lock them into place with the clamping stem (4).

Return the valve body (1) to the base (7) and close by turning it clockwise, making sure that the O-ring (6) is situated in its place in the base of the valve (7).

Remember to open the service valve after the servicing.

### PARTS SPECIFICATION

NO.	DESCRIPTION	MATERIAL
1.	Body	Reinforced Nylon
2.	Drainage Elbow	Polypropylene
3.	Rolling Seal	E.P.D.M.
4.	Clamping Stem	Reinforced Nylon
5.	Float	Foamed Polypropylene
6.	O-ring	Buna-n
7.	Base	Reinforced Nylon / Brass

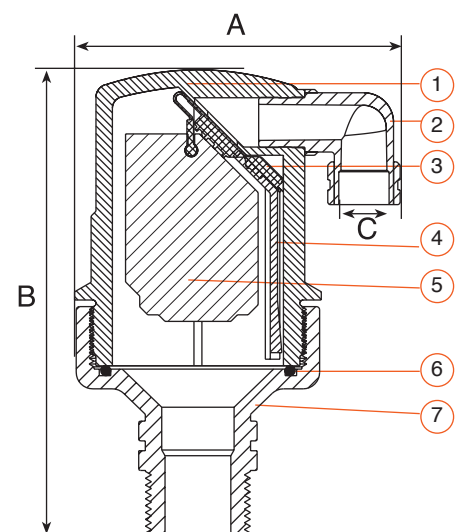

## TROUBLESHOOTING

SYMPTOM	CAUSE	CORRECTIVE ACTION
Right angle outlet is broken.	Valve was hit or mishandled.	Easy to replace: gently pry off the outlet with screwdriver Pressure insert the new right angle using a plastic hammer. Replacement part can be ordered from A.R.I. <b>Note:</b> The part is not mandatory for the function of the valve.
Outlet thread size needed in order to attach a drainage hose.	End user needs to connect a drainage pipe from the valve outlet in order to drain excess water.	D040 has 3/8" female thread. 2" D040 has 1 1/4" female thread. End of pipe must be left open in order for valve to function.
Built-in plastic screen is not accepted by health department.	This is an above ground installation.	ARI offers an approved 316 stainless screen that threads into the 2" valve. GSM in California has made one for the 1" valve.
Plastic body and/or base not acceptable.	Offer the cast iron or stainless steel body. Also offer the bronze or stainless steel base.	We provide several alternatives for those who do not want plastic.
Valve spits water.	This is normal at start up and during pressure test. Could be debris in the sealing mechanism.	Open the valve. Clean and check integrity of the sealing mechanism and O-ring seals.
Valve is continuously leaking.	Line pressure issues, (inadequate pressure), or debris lodged in seal or o-rings.	Check line pressure. It needs at least 3 psi to seal tight. Is the valve on a booster pump? Can be installation issue if valve is level with the water level in a tank - there is no pressure to seal. Open valve and clean sealing mechanism, check the rolling seal and o-rings for wear or tear. Replace if necessary.
Valve leaks from threads.	Plastic threads stripped.	Check for cross-threading. Replace bottom of valve or offer the cast metal base.

