



PRESSURE REGULATOR GUIDE

AGRICULTURAL, RESIDENTIAL & COMMERCIAL IRRIGATION
Low Pressure - High Performance





WHY PRESSURE REGULATORS?

Every system experiences pressure fluctuations resulting in unwanted flow deviations and over and under-watering.

Irrigation systems distribute a predetermined amount of water over a specific area. However, every system experiences pressure fluctuations resulting in unwanted flow deviations and over- and under-watering.

Pressures fluctuate for several reasons including elevation changes within the irrigated area and pressure loss through pipes and fittings. In solid set, nursery, residential and commercial landscape systems, pressures can fluctuate when zones cycle on or off. Pressure issues are also common on large projects with multiple wells providing water as system demands change. In mechanical move

systems, pressures are also affected by activation of end guns and corner arms.

It is important to maintain the correct operating pressure to sprinklers for optimum droplet size and radius of throw. In addition, regulation is imperative to properly meter application of fertilizers and herbicides through the irrigation system. Running systems at a controlled low pressure can help extend sprinkler and system life. Proper use of pressure regulators helps maintain the overall efficiency of an irrigation system.

Pressure regulators are available in a variety of models to match specific flow and pressure needs.

PRESSURE CHANGE	DESIGN PRESSURE						
	6 psi (0.41 bar)	10 psi (0.69 bar)	15 psi (1.03 bar)	20 psi (1.38 bar)	30 psi (2.07 bar)	40 psi (2.76 bar)	50 psi (3.45 bar)
1 psi (0.69 bar)	16.7	10.0	6.7	5.0	3.3	2.5	2.0
2 psi (0.138 bar)	33.3	20.0	13.3	10.0	6.7	5.0	4.0
3 psi (0.207 bar)	50.0	30.0	20.0	15.0	10.0	7.5	6.0
4 psi (0.276 bar)	66.7	40.0	26.7	20.0	13.3	10.0	8.0
5 psi (0.345 bar)	83.3	50.0	33.3	25.0	16.7	12.5	10.0
6 psi (0.414 bar)	100.0	60.0	40.0	30.0	20.0	15.0	12.0
7 psi (0.483 bar)	N/A	70.0	46.7	35.0	23.3	17.5	14.0
8 psi (0.552 bar)	N/A	80.0	53.3	40.0	26.7	20.0	16.0
PERCENTAGE OF PRESSURE VARIATION (%)							

Pressure regulators are recommended if there is a 20% pressure variation.

A 20% pressure variation equals a 10% flow variation.

The lower a system's operating pressure, the more critical it is to control pressure accurately.

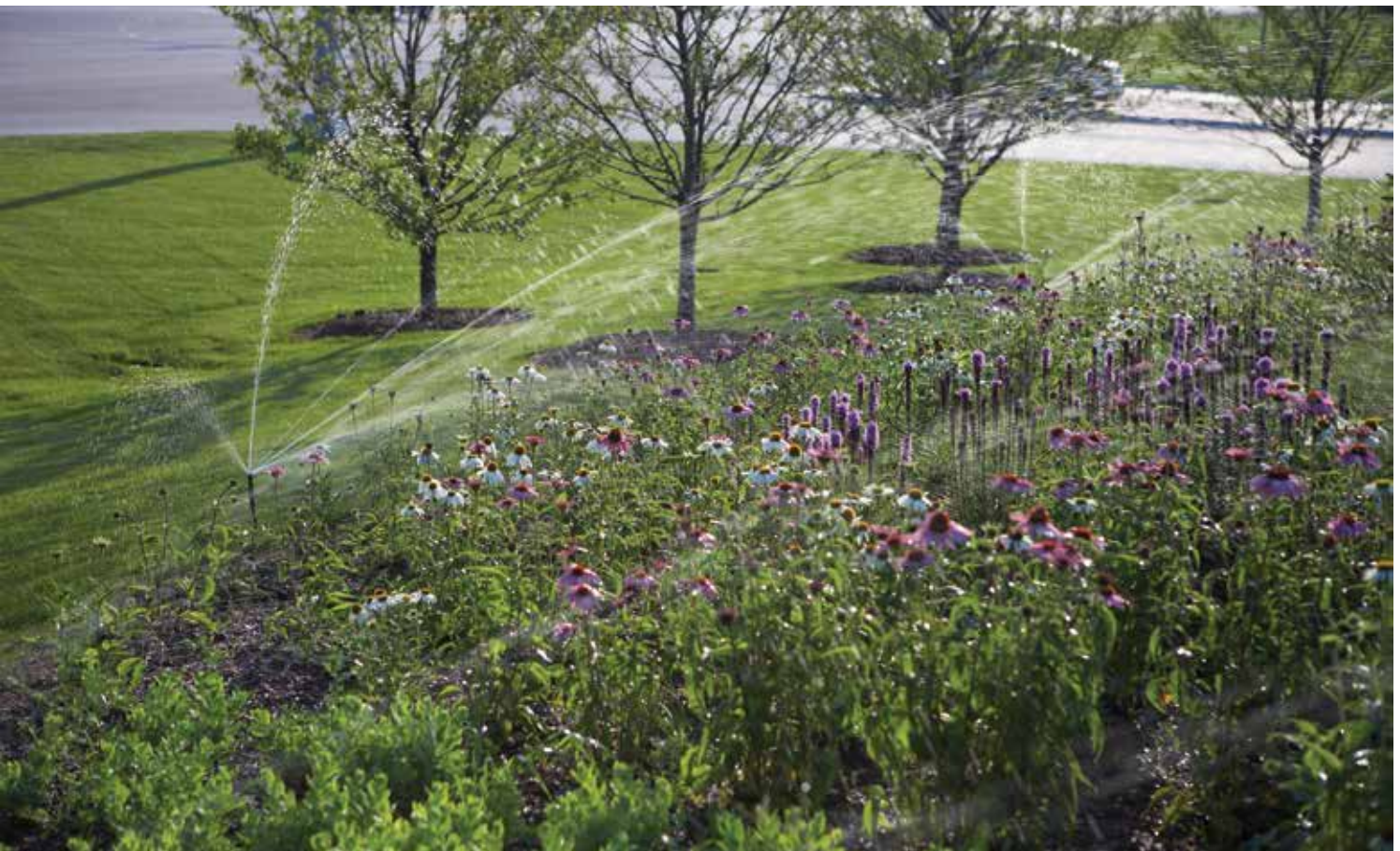

WHY SENNINGER?

Senninger Irrigation recognizes and promotes the importance of maintaining correct system pressure to conserve water and energy. Senninger introduced the first in-line pressure regulator to the irrigation industry in 1966. Throughout the years, several models have been developed to meet a variety of installation needs - mechanized systems, solid set field, nurseries and greenhouses, and residential and commercial landscape. Today, Senninger pressure regulators are known worldwide for their accuracy and reliable performance.

PRESSURE REGULATOR ACCURACY

The design and materials used to manufacture pressure regulators greatly impact their accuracy. Senninger pressure regulators are designed and built to rigorous quality standards. They are 100% water-tested for accuracy at our in-house facilities before they are packaged and shipped. Senninger pressure regulators are backed with a two-year warranty on materials, workmanship, and performance.

PRESSURE REGULATOR MODELS

LOW FLOW



PRLG

PRODUCT SPECS	PRLG
Flow Range	0.5 - 7 gpm (114 - 1590 L/hr)
Preset Operating Pressure	10 - 40 psi (0.69 - 2.76 bar)
Maximum Inlet Pressure*	90 - 120 psi (6.20 - 8.27 bar)
Inlet Sizes	3/4" F hose, 3/4" F NPT
Outlet Sizes	3/4" M hose, 3/4" M NPT



PRL

PRODUCT SPECS	PRL
Flow Range	0.5 - 8 gpm (114 - 1817 L/hr)
Preset Operating Pressure	6 - 40 psi (0.41 - 2.76 bar)
Maximum Inlet Pressure*	90 - 120 psi (6.20 - 8.27 bar)
Inlet Sizes	3/4" F NPT, 3/4" F hose
Outlet Sizes	3/4" F NPT



HIGH FLOW



PRHF

PRODUCT SPECS	PR-HF
Flow Range	10 - 32 gpm (2271 - 7268 L/hr)
Preset Operating Pressure	10 - 50 psi (0.69 - 3.45 bar)
Maximum Inlet Pressure*	90 - 130 psi (6.20 - 8.96 bar)
Inlet Sizes	1 1/4" F NPT, 1 1/4" F BSPT
Outlet Sizes	1" F NPT, 1 1/4" F NPT, 1" F BSPT, 1 1/4" F BSPT



PRU

PRODUCT SPECS	PRU
Flow Range	20 - 100 gpm (4543 - 22713 L/hr)
Preset Operating Pressure	10 - 60 psi (0.69 - 4.14 bar)
Maximum Inlet Pressure*	90 - 140 psi (6.20 - 9.65 bar)
Inlet Sizes	2" F NPT, 2" F BSPT
Outlet Sizes	2" F NPT, 2" F BSPT



PRXF

PRODUCT SPECS	PRXF
Flow Range	20 - 100 gpm (4543 - 22713 L/hr)
Preset Operating Pressure	10 - 60 psi (0.69 - 4.14 bar)
Maximum Inlet Pressure*	90 - 140 psi (6.20 - 9.65 bar)
Inlet Sizes	3" F slip
Outlet Sizes	3" F slip

*Senninger pressure regulators are recommended for outdoor use only. Not NSF certified.
* Maximum recommended inlet pressure not to exceed 80 # psi (5.52 bar) above nominal model pressure.*

MEDIUM FLOW



PSR-2

PRODUCT SPECS	PSR & PSR-2
Flow Range	0.5 - 15 gpm (114 - 3407 L/hr)
Preset Operating Pressure	6 - 50 psi (0.41 - 3.45 bar)
Maximum Inlet Pressure*	90 - 130 psi (6.20 - 8.27 bar)
Inlet Sizes	¾" F NPT
Outlet Sizes	¾" F NPT



PMR-MF

PRODUCT SPECS	PMR-MF
Flow Range	2 - 20 gpm (454 - 4543 L/hr)
Preset Operating Pressure	6 - 60 psi (0.41 - 4.14 bar)
Maximum Inlet Pressure*	90 -140 psi (6.20 - 8.27 bar)
Inlet Sizes	¾" F NPT, 1" F NPT, 1" F BSPT
Outlet Sizes	¾" F NPT, 1" F NPT, 1" F BSPT



LIMIT VALVE



PRLV

PRODUCT SPECS	PRLV
Flow Max	18 gpm (4088 L/hr)
Preset Operating Pressure	30 - 60 psi (2.07 - 4.14 bar)
Maximum Inlet Pressure	125 psi (8.62 bar)
Inlet Sizes	¾" F NPT, 1" F NPT
Outlet Sizes	¾" F NPT, 1" F NPT

Pressure Regulating Limit Valves are designed to control pressure when there is no water flow and have a rubber washer in the seat and are generally used where there is a shut-off valve downstream. When this shut-off valve is closed, the t-stem flow-passage closes and seals on the rubber seat, thus limiting the PRLV outlet pressure to only 10 to 15 psi above its normal regulating pressure. This helps protect downstream components from potential damage due to high static upstream water pressure.



PRXF-LV

PRODUCT SPECS	PRXF-LV
Flow Max	75 gpm (17034 L/hr)
Preset Operating Pressure	30 - 60 psi (2.07 - 4.14 bar)
Maximum Inlet Pressure	125 psi (8.62 bar)
Inlet Sizes	3" F slip
Outlet Sizes	3" F slip

With a standard regulator, when the downstream shut-off valve is closed and there is pressure but no flow through the device, the t-stem is unable to completely seal against the harder seat. The high inlet pressure eventually equalizes across the regulator and up to the valve. Upon opening the shut-off valve, a high-pressure surge could possibly damage downstream meters, sprinklers or other plumbing components.

Senninger pressure regulators, PRLV, and PRXF-LV are recommended for outdoor use only. Not NSF certified.

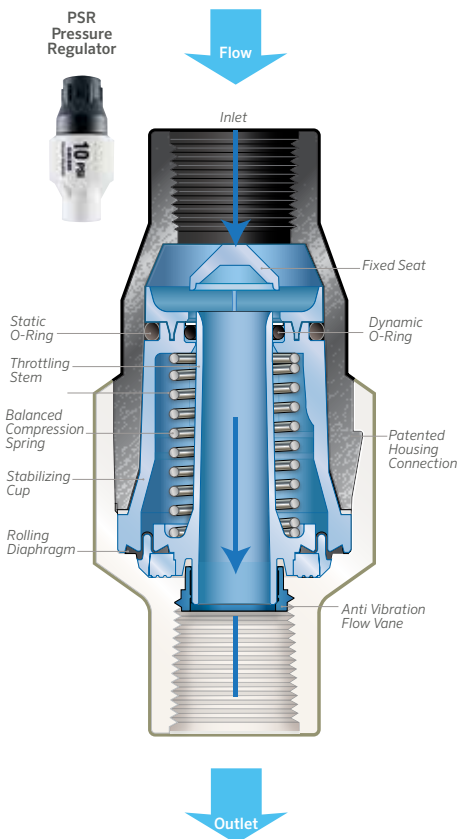

HOW SENNINGER PRESSURE REGULATORS WORK

A water pressure regulator is a device that works like an automatic valve to limit higher pressure to a desired constant lower pressure.

An in-line pressure regulator contains a hollow cylindrical housing with a centrally-mounted stationary seat near the inlet. Inside is a movable tubular stem (throttling stem or t-stem) surrounded by a spring with a diaphragm attached near the downstream end. The diaphragm and O-rings isolate the spring to keep it dry. Water flows through the inlet, around the seat and through the t-stem. Water pressure acting on the diaphragm forces the spring to compress, pushing the t-stem toward the seat. The closing of the area between the seat and the t-stem reduces the water pressure on the diaphragm. The balance between the force on the diaphragm and spring resistance establishes the outlet pressure. Senninger uses springs with different compressive loads to deliver various preset water pressures from 6 to 60 psi (0.41 to 4.14 bar).

LOW HYSTERESIS

Hysteresis is the difference in regulator outlet pressure from when the inlet pressure is increasing to a certain psi/bar above the regulating pressure, and then decreasing to that same psi/bar. The hysteresis effect may cause flow values to vary from their preset values. Senninger pressure regulators have extremely low hysteresis which is important for accurate regulation with varying inlet pressures.

LOW FRICTION LOSS

Hydraulic friction loss is what makes a regulator work. Senninger recommends 5 psi (0.34 bar) higher inlet pressure than expected outlet pressure.

WARRANTY

MATERIALS & WORKMANSHIP

Senninger pressure regulators are warranted for a period of two years from date of original manufacture to be free of any defects in material or workmanship. PRLV limit valves and mixing models are warranted for one year.

PERFORMANCE

Senninger pressure regulators used for ag, turf and nursery irrigation are warranted to maintain their original performance for a period of two years from date of original manufacture when installed and operated in accordance with Senninger's written specifications and used for their ordinary purpose. PRLV limit valves are warranted for materials and workmanship.

Senninger's complete product warranty is available online at <https://www.senninger.com/senninger-warranty>



Senninger's commitment to world-class products, local support and technical expertise ensure we provide the most efficient and reliable agricultural irrigation solutions available in the world today.

A handwritten signature in white ink, appearing to read 'S. D. Abernethy', is centered on the page.

Steve Abernethy, President of Senninger Irrigation